

COILS

HOT ROLLED RIBBED B500B (BE500TS)

Diameter (mm)	Minimum coil weight (kg)	Maximum coil weight (kg)
8	2500	4700
10	2500	4700
12	2500	4700
14	2500	4700
16	2500	4700

COMMENTS

- Different coil weights upon request
- Our coils can unwind to the left or to the right

TARGET DIMENSIONS

	2500 (kg)	3000 (kg)	4000 (kg)	4700 (kg)
Int. \emptyset	600	600	600	600
H (mm)	700	700	980	980
\emptyset (mm)	1200	1200	1200	1300

GRADE B500B - BE500TS

Mechanical characteristics	Yield strength Re (Mpa)	Stress ratio Rm/Re	Total elongation at max force Agt %
Minimum characteristic value Cv	500	1,08	5,5

PRODUCERS MARK

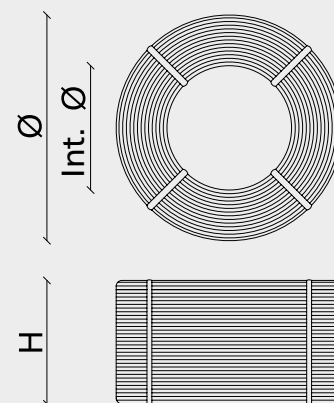
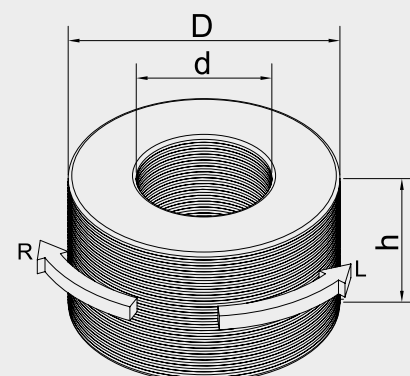
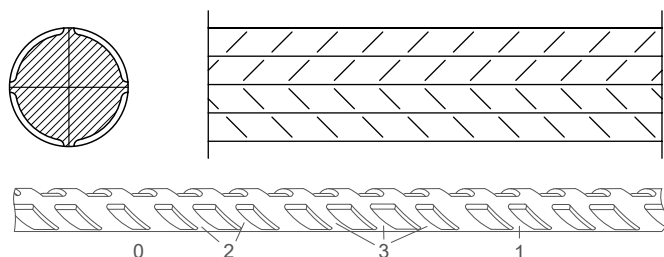

Certificates Intersig NV



Certificates Van Merksteijn International



Certificates Intersig France



For the up to date scope on our certificates, we would like to refer you to our website.