

COILS

COLD DRAWN SMOOTH B500A

Diameter (mm)	Minimum coil weight (kg)	Maximum coil weight (kg)
4	1600	3000
4,5	1600	3000
5	1600	3000
5,5	1600	3000
6	1600	4700
7	1600	4700
8	1600	4700
10	1600	4700
12	1600	4700

COMMENTS

- Diameters $\phi 5$ are quality B500 instead of B500A and are not certified for any country
- Only diameters 6, 8, 10 and 12 are certified for Germany
- Different coil weights upon request
- Our coils can unwind to the left or to the right

TARGET DIMENSIONS

	1600 (kg)	2000 (kg)	2500 (kg)	3000 (kg)	4000 (kg)	4700 (kg)
Int. ϕ	600	600	600	600	600	600
H (mm)	700	700	700	700	980	980
ϕ (mm)	1000	1100	1200	1200	1200	1300

GRADE B500A

Mechanical characteristics	Yield strength Re (Mpa)	Stress ratio Rm/Re		Total elongation at max force Agt %	
		$5 \leq d \leq 5.5$	$d \geq 6$	$5 \leq d \leq 5.5$	$d \geq 6$
Minimum characteristic value Cv	500	1,03	1,05	2,5	3,5

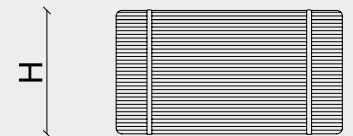
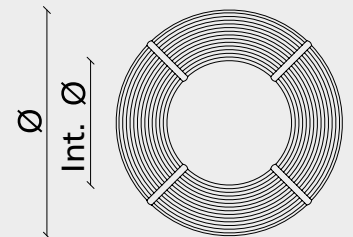
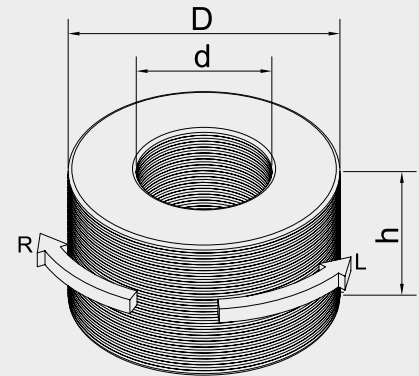

Certificates Intersig NV



Certificates
Van Merksteijn
International



Certificates
Intersig France



For the up to date scope on our certificates, we would like to refer you to our website.

 **INTERSIG**